

BITS-Pilani Dubai,
Dubai International Academic City, Dubai
IV Year, II Semester, Academic Year 2008-09
Evaluation Component : Comprehensive Examination (Closed Book)

CHE C441 / INSTR C451 PROCESS CONTROL (Elective)

Date : 21st May 2009
Duration: 3 hours

Max. Marks: 90
Weightage: 25%

- Note:- 1. ANSWER ALL QUESTIONS
 2. Make assumptions, if any, but explicitly indicate the assumptions made

1)

- a) Sketch a flow chart depicting the major steps in the development of process Control System, Indicating distinctly the engineering and the activities involved and the information base, if any, to be used for each activities (3 M)
- b) Two tanks are connected together in an unusual way as in the figure below:

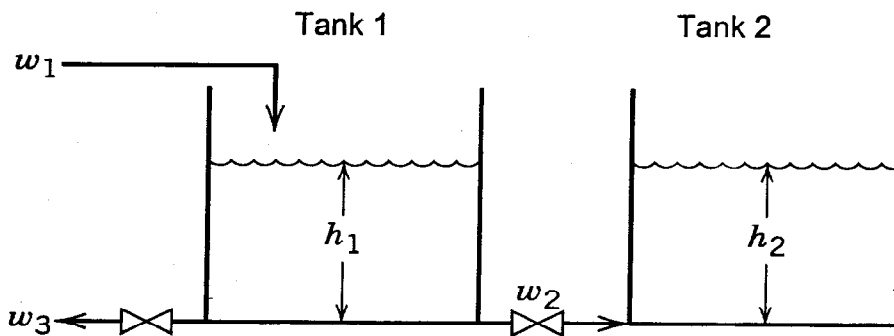

- i) Develop a model for this system that can be used to find h_1 , h_2 , w_2 , and w_3 as functions of time for any given variations in inputs. (4 M)
- ii) Perform a degree of freedom analysis. Identify all input and output variables (3 M)

Notes: The density of the incoming liquid, ρ , is constant. The cross-sectional areas of the two tanks are A_1 and A_2 . w_2 is positive for flow from Tank 1 to Tank 2. The two valves are linear with resistances R_1 and R_2 . Assume: (i) P_1 , P_2 , P_a are the pressure in Tank 1, Tank 2, and ambient pressure respectively. (ii) g and g_c are the acceleration due to gravity and its conversion factor.

2)

- a) Summarize a systematic and self-explanatory procedural steps that one needs to follow in "developing a dynamic model of typical process from its first principles" (5 M)
- b) The dynamic model between an output variable y and an input variable u can be expressed by:

$$\frac{d^2 y(t)}{dt^2} + 3 \frac{dy(t)}{dt} + y(t) = 4 \frac{du(t-2)}{dt} - u(t-2)$$

- i) Will this system exhibit an oscillatory response after an arbitrary change in u ? (2.0 M)
- ii) What is the steady state gain? (1.0 M)
- iii) For a step change in u of magnitude 1.5, what is $y(t)$? (2.0 M)

(Please Turn Over to Page 2)

3)

- a) Draw a flow chart that depicts the step-by-step procedure for developing the transfer function model from dynamic process model. (3.0 M)
- b) A step change from 15 to 31 psi in actual pressure results in measured response from a pressure indicating element shown in the figure below:

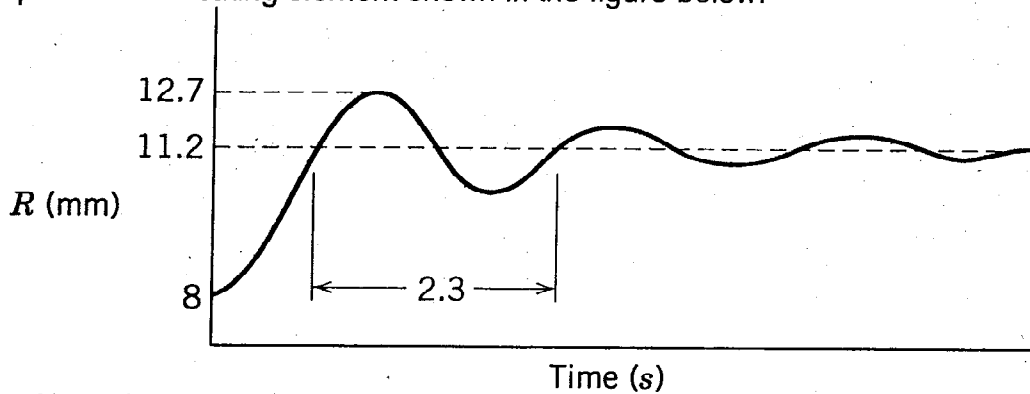

- i) Assuming second-order dynamics calculate all important parameters and write an approximate transfer function in the form given below: (4.0 M)
- $$\frac{R'(s)}{P'(s)} = \frac{K}{\tau^2 s^2 + 2\tau\xi s + 1}$$
- where: R' is the instrument output deviation (mm); P' is the actual pressure deviation (psi).
- ii) Write an equivalent differential equation model in terms of actual (not deviation) variables. (3.0 M)

4)

- a) For the process described by the exact transfer function given below,
 $G(s) = [5(1-s)e^{-2s}] / \{(12s+1)(3s+1)(0.2s+1)(0.05s+1)\}$
 Using Skogestad's "Half Rule", derive an approximate model in the form of a second order-plus time delay to describe this process. (5.0 M)
- b) Fit an integrator plus time-delay model to a unit step response, shown in the figure below, for $t \leq 15$.

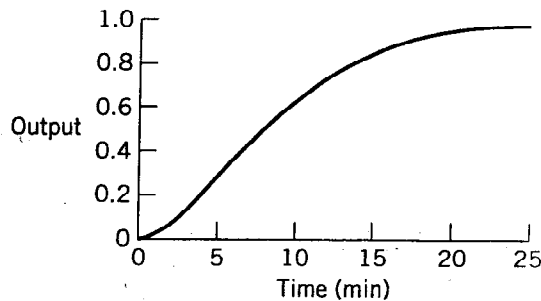

The step response has been normalized by steady state gain. Compare the experimental response with the response predicted from the model (5.0 M)

5)

- a) Define the meaning of each of the following feedback controller phenomenon
- Reset windup (2 M)
 - Derivative kick (2 M)
 - Reverse and Direct Action in proportional control. (2 M)

(Please Turn Over to Page 3)

- b) A process temperature sensor/transmitter in a fermentation reactor exhibits second-order dynamics with time constants of 1 s and 0.1 s. If the quantity being measured changes at a constant rate 0.1°C/s ,
- What is the maximum error that this instrument combination will exhibit? (2 M)
 - What is the effect of neglecting the smaller time constant? (2 M)

6)

- a) Suggest a modification of the Direct Synthesis approach that will allow it to be applied to open unstable process (Hint: First stabilize the process using proportional-only feedback controller). Draw a block diagram for your proposed control scheme. (5 M)
- b) The block Diagram of feedback control system is shown in the figure below. Determine the values of K_c that result in stable closed loop system. (5 M)

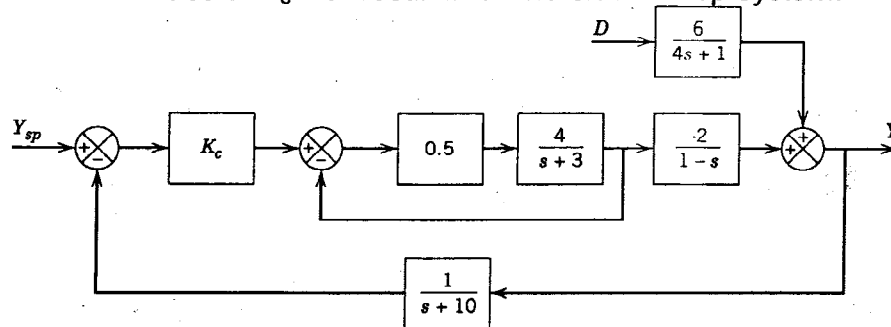

7)

- a) Write short notes on the following:
- Relay Auto-Tuning
 - Adaptive Control System
 - Aliasing in Digital control
- b) A perfectly stirred tank is used to heat a flowing liquid. The dynamics of the system have been determined to be approximately as shown in the figure below:

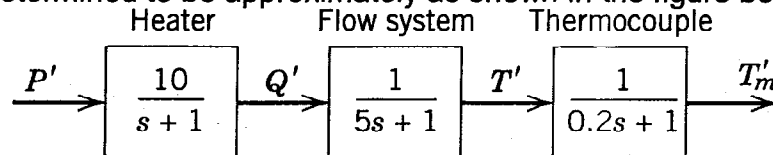

where: P is the power applied to the heater; Q is the heating rate of the system; T is the actual temperature in the tank; T_m is the measured temperature. A test has been made with P' varied sinusoidal as: $P' = 0.5 \sin 0.2t$. For these conditions, the measured temperature is: $T'_m = 3.464 \sin (0.2t + \Phi)$. Find a value for the maximum error bound between T' and T'_m if the sinusoidal input has been applied for a long time.

8)

- a) Mention the steps introduced by Ziegler and Niclos for controller tuning using the continuous cyclic method. (5.0 M)
- b) It is desired to control liquid level h_2 in the storage tank system shown in the figure below by manipulating flow rate q_3 . Disturbance variable q_1 can be measured. Assuming as in A through D (listed in the next page),

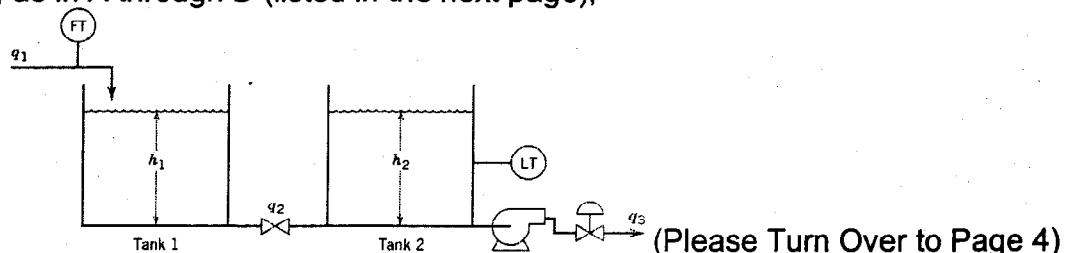

(A) the two tanks have uniform cross sectional areas, A_1 and A_2 , respectively. (B) the valve on the exit line of Tank 1 acts as a linear resistance with a flow-head relation, $q_2 = (h_1 - h_2)/R$. (C) The transmitters and control valve are pneumatic instruments that have negligible dynamics. (D) The pump operates so that flow rate q_3 is independent of h_2 when the control valve stem position is maintained constant.

- i) Draw a block diagram for a feed forward-feedback control system (2.0 M)
 ii) Derive an ideal feed forward controller based on a steady-state analysis (3.0 M)
- 9) a) Draw a block diagram that depicts a typical Model Predictive Control and offer, in brief, an overview of the same. (5.0 M)
- b) The mean arterial pressure P in a patient is subjected to a unit step change in feed flow rate F of a drug. Normalized response data are shown below: (5 M)

Time (Min)	P
0	0
1	0.495
2	0.815
3	1.374
4	1.681
5	1.889
6	2.078
7	2.668
8	2.533
9	2.908
10	3.351

Previous experience has indicated that the transfer function,

$$\frac{P(s)}{F(s)} = \frac{5}{10s + 1}$$

provides an accurate dynamic model. Filter these data using an exponential filter with an α value of 0.5. Graphically compare the noisy data, filtered data, and the analytical solution for the transfer function model for a unit step input. (5.0 M)

WISH YOU ALL THE BEST

BITS-Pilani Dubai,
Dubai International Academic City, Dubai
IV Year, II Semester, Academic Year 2008-09

Evaluation Component : TEST-II (Open Book)
CHE U441 / INSTR U451 PROCESS CONTROL (Elective)

Date : 3rd May 2009
Duration: 50 mts

Max. Marks: 20
Weightage: 20%

Note:- 1. ANSWER ALL QUESTIONS
 2. Make assumptions, if any, but explicitly indicate the assumptions made

- 1) A stirred –tank blending system with a bypass stream is shown in the figure. The control objective is to control the composition of a key component in exit stream , x_4 .The chief disturbance variables are the mass fractions of the key component in inlet streams, x_1 and x_2 .Using the information given below, discuss which flow rate should be selected as the manipulated variable
- a) inlet flow rate w_2 (3 Marks)
 b) the bypass fraction for exit flow rate , w_4 (3 Marks)
- Your choice reflect both steady-state and dynamic consideration.

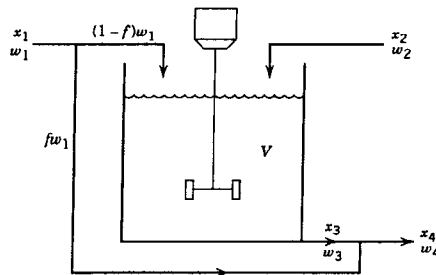

- 2) A feedback control system has the open-loop transfer function:
 $G_{OL}(s)=0.5K_c e^{-3s} / (10s+1)$.
 Determine the values of K_c for which the closed-loop system is stable using Routh Stability Criterion and a 1/1 Pade approximation for e^{-3s} . (3 Marks)
- 3) The liquid level in a reboiler of a steam-heated distillation column is to be controlled by adjusting the control valve on the steam line ,as shown in the figure. The process transfer functions has been empirically determined to be

$$\frac{H(s)}{P_s(s)} = \frac{-1.6(1 - 0.5s)}{s(3s+1)}$$
 Where H denotes the liquid level (in inches) and P_s is the stream pressure (in psi).The level transmitter and control valves have negligible dynamics and steady state gains of $K_m = 0.5$ and $K_v = 25$ (dimensionless) ,respectively. Design a PI level controller using Direct Synthesis method. Justify your choice of τ_c (4 Marks)

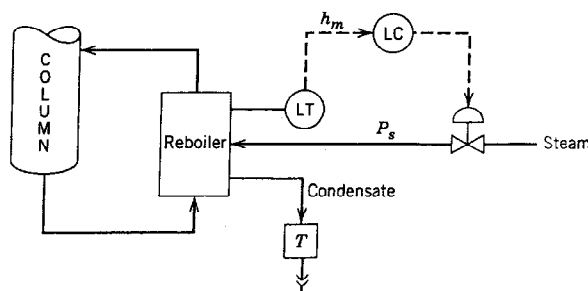

4) Consider the Cascade control system shown in Figure below:

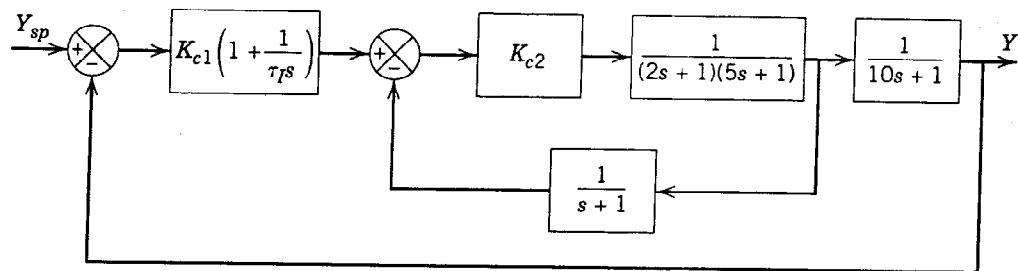

- Specify K_{c2} , so that the gain margin > 1.7 and phase margin $> 30^\circ$ for the slave loop (2.5 Marks)
- Then specify K_{c1} and t_i for the master-loop using the Ziegler-Nichols tuning relation. (2.5 Marks)

STUDENT CAN CHOOSE TO ANSWER ANY ONE FROM THE FOLLOWING

5) A data acquisition system for environmental monitoring is used to record the temperature of an air stream as measured by a thermocouple. It shows an essentially sinusoidal variation after about 15 s. The maximum recorded temperature is 127°F , and the minimum is 119°F at 1.8 cycles per min. It is estimated that the thermocouple has a time constant of 4.5 s. Estimate the actual maximum and minimum air temperatures. (2 Marks)

OR

6) A process that can be modelled as a time delay is controlled using a proportional feedback controller. The control valve and measurement device have negligible dynamics and steady state gains of $K_v=0.5$ and $K_m=1$ respectively. After a small set-point change is made, a sustained oscillation occurs, which has a period of 10min. What controller gain is being used? (2 Marks)

OR

7) For the liquid storage system shown in Figure below (see next page), the control objective is to regulate liquid level h_2 despite disturbances in flow rates q_1 and q_4 . Flow rate q_2 can be manipulated. The two hand valves have the following flow-head relations: $q_3=C_1(\text{square root of } h_1)$ and $q_5=C_2(\text{square root of } h_2)$. Assuming that the flow transmitters and the control valve have negligible dynamics. Draw a block diagram for a feedforward control system for the case where q_1 can be measured and variations of q_4 can be neglected. (2 Marks)

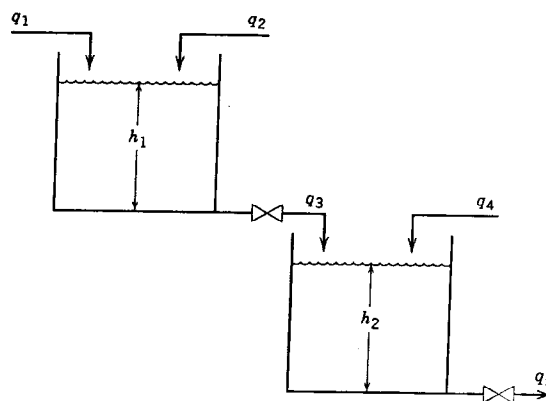

WISH YOU ALL THE BEST

**BITS-Pilani Dubai,
Dubai International Academic City, Dubai
IV Year, II Semester, Academic Year 2008-09**

Evaluation Component : TEST-I (Closed Book)

CHE U441 / INSTR U451 PROCESS CONTROL (Elective)

**Date : 29th March 2009
Duration: 50 mts**

**Max. Marks: 25
Weightage: 20%**

Note:- 1. ANSWER ALL QUESTIONS
2. Make assumptions, if any, but explicitly indicate the assumptions made

1)

- a) Sketch a flow chart depicting the major steps in the development of process Control System, Indicating distinctly the engineering and the activities involved and the information base, if any, to be used for each activities. (2.0 M)
- b) A perfectly stirred, constant – volume tank has two input streams, both consisting of the same liquid. The temperature and the flow rate of each of the streams can vary with time.

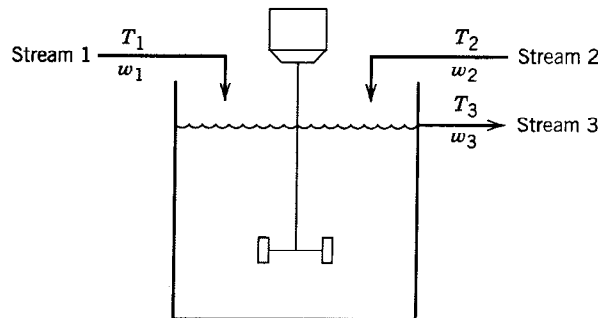

Derive a dynamic model that will describe transient operation. Make a degree of freedom analysis assuming that both stream1 and 2 come from upstream units (i.e their flow rates and temperature are known function of time) (2+1=3.0 M)

2)

- a) The start-up procedure for batch reactor includes a heating step where the reactor temperature is gradually heated to the nominal operating temperature of 75°C. The desired temperature profile $T(t)$ is shown in the figure . What is $T(s)$.. (2.0 M)

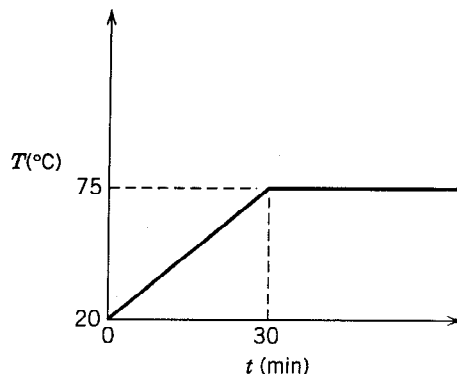

(Please Turn Over to Page 2)

b) For the process modeled by

$$2 \frac{dy_1}{dt} = -2y_1 - 3y_2 + 2u_1$$

$$\frac{dy_2}{dt} = 4y_1 - 6y_2 + 2u_1 + 4u_2$$

Find the four transfer functions relating the outputs (y_1, y_2) to the inputs (u_1, u_2). Note that u and y are deviation variables. (3.0 M)

3)

a) A tank used to dampen liquid flow rate surges is known to exhibit second order dynamics. The input flow rate changes suddenly from 120 to 140 gal/min. An operator notes that the tank level changes as follows:

Before input change: Level = 6 ft and steady

Four minutes later: Level = 11 ft

Forty minutes later: Level = 10 ft and steady

i) Find a transfer function model that describes this process, at least approximately.

Evaluate all parameters in your model, including units. (2.0 M)

ii) Is your model unique? Why or why not? (1.0 M)

b) State Skogestad's Half Rule. Using this rule, for the process described by the exact transfer function $G(s)$ indicated below, find the approximate transfer function in the SOPTD form. (1+2=3.0M)

$$G(s) = \frac{5e^{-s}}{(10s+1)(4s+1)(s+1)(0.2s+1)}$$

4)

a) An operator introduces a step change in the flow rate q_i to a particular process at 3:05 A.M., changing the flow from 500 to 540 gal / min. The first change in the process temperature T (initially at 120°F) comes at 3:09 A.M. After that, the response in T is quite rapid, showing down gradually until it appears to reach a steady-state value of 124.7 °F. The operator notes in the logbook that there is no change after 3:34 A.M. What approximate transfer function might be used to relate temperature to flow rate for this process in the absence of more accurate information? What should the operator do next time to obtain a better estimate? (1+1=2.0M)

b) Briefly explain about Control Valve Positioners and Control Valve sizing (1.5+1.5 = 3.0M)

5) Explain about any two out of three common enhancements of the basic PID Controllers that greatly improve their performance. (4.0 M)

WISH YOU ALL THE BEST

BITS,PILANI-DUBAI CAMPUS
Academic City, Dubai
Year III – semester 2 2008-2009

Quiz 3

Course No. CHE UC441
Date : April ,2009

Time 20 minutes

Course Title : Process Control
Max Mrks=5

NAME:-----

ID:.....

Question 1:

[1=1+1=3 M]

- a- Mention the main steps in control system design
- b- What is the relation between process degree of freedom and control degree of freedom
- c- Mention the typical layers of protection in a modern chemical plant

Q2:

[2M]

A Temperature control system for distillation column is shown in the figure. The temperature T of a tray near the top of the column is controlled by adjusting the reflux flow rate. Draw a block diagram for this feedback control system. You may assume that both feed flow F and feed composition X_F are disturbance variables and that all of the instrumentation, including the controller, is pneumatic.

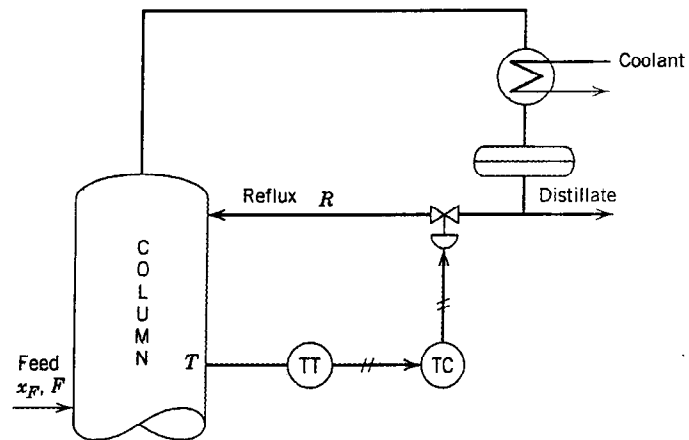

BITS,PILANI-DUBAI CAMPUS
Academic City, Dubai
Year III – semester 2 2008-2009
Quiz 2

Course No. CHE UC441

Date : Marh 11,2009

Time 20 minutes

Course Title : Process Control

Max Mrks=5

NAME:-----

ID:.....

Question 1:

[1.5 M]

Consider the following transfer function :

$$G(s)=Y(s)/U(s)=5/10s+1$$

- a- what is the steady state gain and time constant
- b- if $U(s) = 2/s$,what is the final value of $Y(t)$

Question 2:

[2M]

A thermocouple has the following characteristics when immersed in stirred bath:

Mass of thermocouple = 1g

Heat capacity of thermocouple =0.25 cal/g °C

Heat Transfer coefficient =20 cal/cm² h °C (for thermocouple and path)

Surface area of thermocouple = 3 cm²

Derive a transfer function model for the thermocouple relating the change in its indicated output T to the change in the temperature of its surroundings Ts assuming uniform temperature ,no conduction in leads,and constant physical properties.

Question 3:

[1.5M]

For the process described by the exact transfer function :

$$G(s) = 5/ (10s+1)(4s+1)(s+1)(0.2s+1)$$

Find an approximate transfer function $\tilde{G}(s) = k e^{-\theta s} / (1+\tau_1 s) (1+\tau_2 s)$ of second order plus time delay form that describes this process using skogestad's method.

BITS,PILANI-DUBAI CAMPUS
Academic City, Dubai
Year III – semester 2 2008-2009

Quiz 1

Course No. CHE UC441

Date : FEB 17,2009

Time 20 minutes

Course Title : Process Control

Max Mrks=5

NAME:-----

ID:-----

Question 1:

[1 M]

What are the different type of process Variables?

1-.....

2-.....

3-.....

Question 2:

[2M]

Draw the hierarchy of process control activities [drawing at behind]

Question 3:

[2M]

Analyze the degree of freedom for the blending model as in the unsteady state component balance equation below:

$$d(V\rho x)/dt = w_1x_1 + w_2x_2 - w_3x_3$$

where V: Tank volume[constant]

p: Density [constant]

w: Mass flow rate ,w1 is constant

x: Mass fraction

Suffixes 1 and 2 represent 2 different inlet streams